

Product Category

107-8-32-S

Part Description

Direct Socketweld/Braze Coupling (Pipe X Tube)

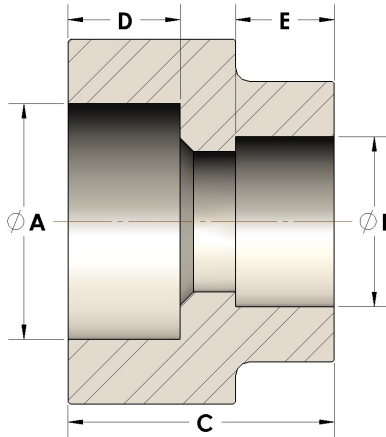

DIMENSIONS

A	2.380
B	2.00
C	2.13
D	0.880

GENERAL

Pressure Rating	4500 PSI
Fitting Material	Carbon Steel, ASTM A108