

Product Category

1380-3-P-OXNB-VC-NO

Product Line

FloMaster® Actuated OXNB Shutoff Valve (1300 Series)

Part Description

1/2" Globe Shutoff Oxygen Actuated Valve, Normally Open

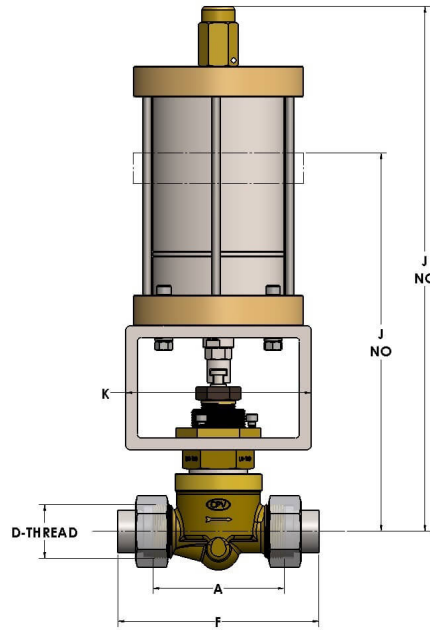

DIMENSIONS

Port Dia.	0.5
A	4.250
CRN	0C16868.2
D-THREAD	1.750"-12UN
F	6.50
J (Normally Open)	12.25
K	6



GENERAL

Pressure Rating	4500 PSI
Temperature Range	-15°F to 400°F (-26°C to 204°C)
Standard Soft Goods	[-C] Viton® Packing & O-Rings
Cartridge Type	Shutoff
Connection Type	O-SEAL® Union Thread
Connection Size	1/2"
Body Material	Naval Brass, ASTM B21, UNS C46400
Bonnet Material	Naval Brass, ASTM B21, UNS C46400
CRN	OC16868.2

OPTIONS

Port & Vent Options	[-PA] Port Above Seat (1/8" NPT), [-PB] Port Below Seat (1/8" NPT), [-VA] Vent Above Seat (3/8"-24 SAE), [-VB] Vent Below Seat (3/8"-24 SAE),
---------------------	---