

Product Category

1480-4-P-OXNB-VC-NO

Product Line

FloMaster® Actuated OXNB Needle Valve (1400 Series)

Part Description

3/4" Globe Needle Oxygen Actuated Valve, Normally Open

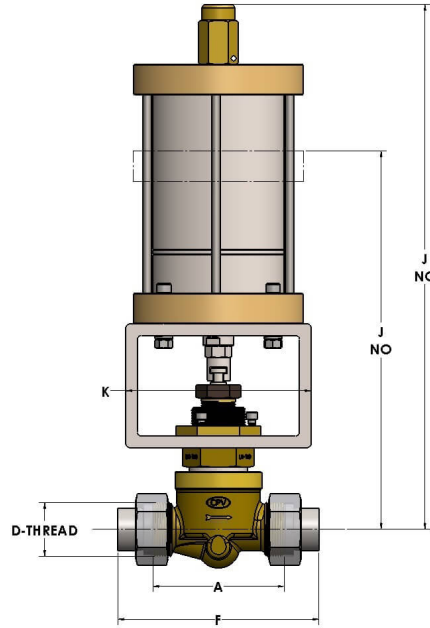

DIMENSIONS

Port Dia.	0.63
A	4.630
CRN	0C16868.2
D-THREAD	2.000"-12UN
F	6.88
J (Normally Open)	13.38
K	8



GENERAL

Pressure Rating	4500 PSI
Temperature Range	-15°F to 400°F (-26°C to 204°C)
Standard Soft Goods	[-C] Viton® Packing & O-Rings
Cartridge Type	Needle
Connection Type	O-SEAL® Union Thread
Connection Size	3/4"
Body Material	Naval Brass, ASTM B21, UNS C46400
Bonnet Material	Naval Brass, ASTM B21, UNS C46400
CRN	OC16868.2

OPTIONS

Port & Vent Options	[-PA] Port Above Seat (1/4" NPT), [-PB] Port Below Seat (1/4" NPT), '[-VA] Vent Above Seat (1/2"-13 SAE), [-VB] Vent Below Seat (1/2"-13 SAE),
--------------------------------	--