

Product Category

151-5

Product Line

NPT Threaded Relief Valves (150 Series)

Part Description

Steel Angle Relief Valve with Female Pipe Thread (NPT) Ends

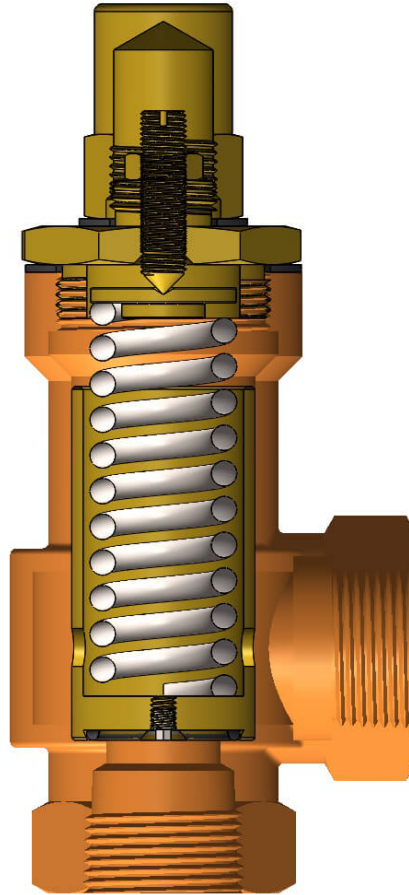

## DIMENSIONS

Overall Length	7
Female Inlet and Outlet (NPT)	1.000"-11.5
Center of Outlet to Bottom	2
Weight (lbs.)	5.3



## GENERAL

<b>Pressure Rating</b>	300 PSI
<b>Temperature Range</b>	-30°F to 250°F (-34°C to 121°C)
<b>Standard Soft Goods</b>	Buna-N O-Rings
<b>Cartridge Type</b>	Relief
<b>Connection Type</b>	Female Pipe Thread (NPT)
<b>Connection Size</b>	1.00"
<b>Body Material</b>	Carbon Steel, ASTM A36/A311, UNS K02600/G10180
<b>Bonnet Material</b>	Carbon Steel, ASTM A36/A311, UNS K02600/G10180

## OPTIONS

<b>Optional Soft Goods</b>	Viton® O-Rings, EPDM O-Rings
----------------------------	------------------------------