

Product Category
Product Line
Part Description

681-7
O-SEAL® Check Valves (600 Series)
1.50" Angle Check Valve with O-SEAL® Ends

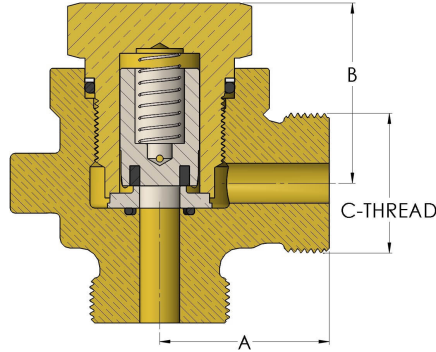

DIMENSIONS

Port Dia.	1.25
A	4.000
B	6.00
C	4.00
C-THREAD	3.063"-12UNS

GENERAL

Pressure Rating	6000 PSI
Temperature Range	-15°F to 275°F (-26°C to 135°C)
Standard Soft Goods	[-C] Viton® O-Rings
Cartridge Type	Check
Connection Type	O-SEAL® Union Thread
Connection Size	1.50"
Body Material	Nickel Aluminum Bronze, ASTM B148, UNS C95800
Bonnet Material	Nickel Aluminum Bronze, ASTM B148, UNS C95800



OPTIONS

Port & Vent Options	[-PA] Port Above Seat (1/4" NPT), [-PB] Port Below Seat (1/4" NPT), [-VA] Vent Above Seat (1/2"-13 SAE), [-VB] Vent Below Seat (1/2"-13 SAE),
Optional Soft Goods	[-B] Polyurethane® Packing and Buna-N O-Rings, [-C] Viton® Packing & O-Rings, [-D] EPDM Packing & O-Rings