

Product Category

H809-10-M

Part Description

Socketweld/braze Tube Cross Assembly

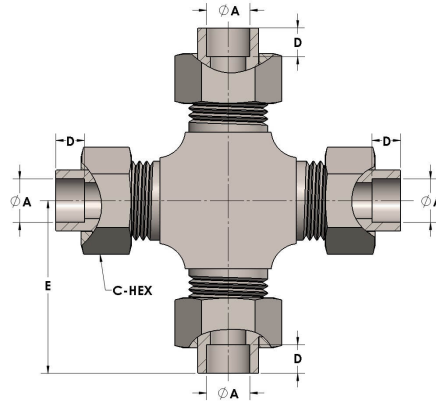

DIMENSIONS

| | |
|-------|-------|
| A | 0.630 |
| C-HEX | 1.13 |
| D | 0.380 |
| E | 2.06 |



GENERAL

| | |
|-----------------------------|--|
| Pressure Rating | 6000 PSI |
| Tailpiece Material | Monel®, ASTM B164, UNS N04405 |
| Threadpiece Material | Monel®, ASTM B564, UNS N04400 |
| O-Ring Material | Viton® Fluorocarbon Type 1, Class 2 (90 durometer) |
| Connection 1 Type | Female Tube Socket |
| Connection 1 Size | 5/8" Tube O.D. (-10) |
| Connection 2 Type | Female Tube Socket |
| Connection 2 Size | 5/8" Tube O.D. (-10) |
| Connection 3 Type | Female Tube Socket |
| Connection 3 Size | 5/8" Tube O.D. (-10) |
| Connection 4 Type | Female Tube Socket |
| Connection 4 Size | 5/8" Tube O.D. (-10) |