

Product Category

H819-08-SS316L

Part Description

Direct Socketweld/Braze Cross (Tube)

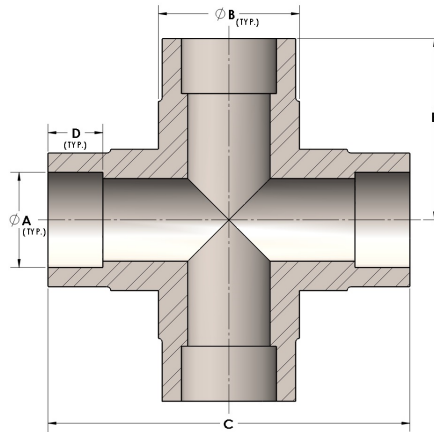

## DIMENSIONS

A	0.500
B	0.75
C	2.13
D	0.310
E	1.06
F	1.44

## GENERAL

Pressure Rating	4500 PSI
Fitting Material	316/L Stainless Steel, ASTM A276, UNS S31600/03