

Product Category

H819-10-M

Part Description

Direct Socketweld/Braze Cross (Tube)

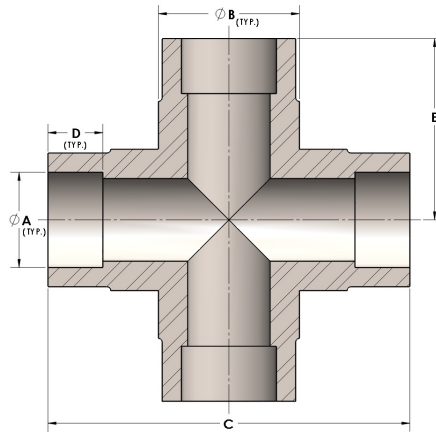

DIMENSIONS

A	0.630
B	0.88
C	2.38
D	0.380
E	1.19
F	1.63

GENERAL

Pressure Rating	6000 PSI
Fitting Material	Monel®, ASTM B164, UNS N04405