

Product Category

H866-10-08-S

Part Description

Direct Weld/Braze Insert (Male Tube X Pipe SW)

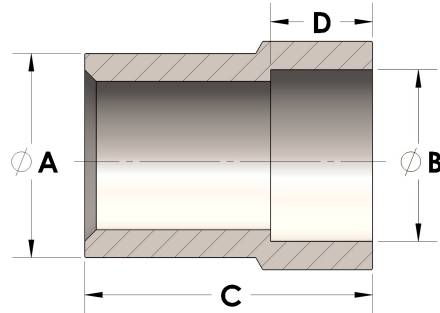

## DIMENSIONS

A	0.630
B	0.85
C	1.38
D	0.380

## GENERAL

Pressure Rating	3000 PSI
Fitting Material	Carbon Steel, ASTM A36/311, UNS K02600/G10180